

VB1
ESC 1:50

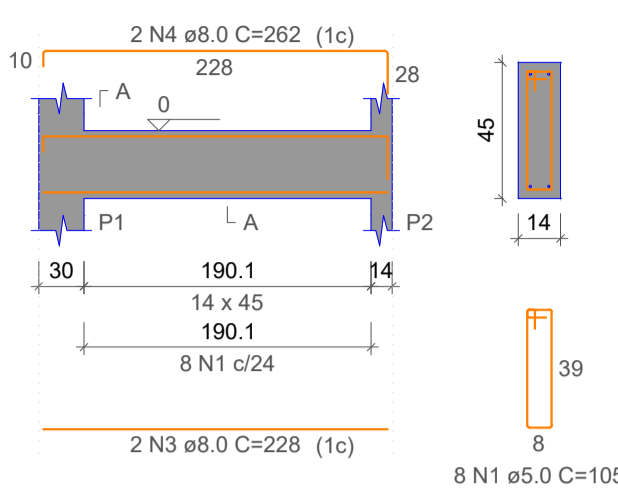

VB2
ESC 1:50

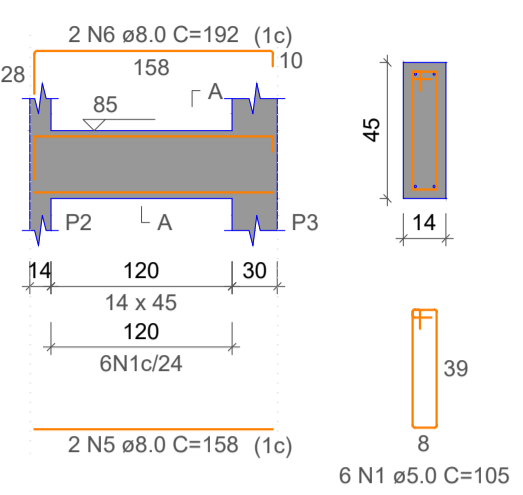

VB3
ESC 1:50

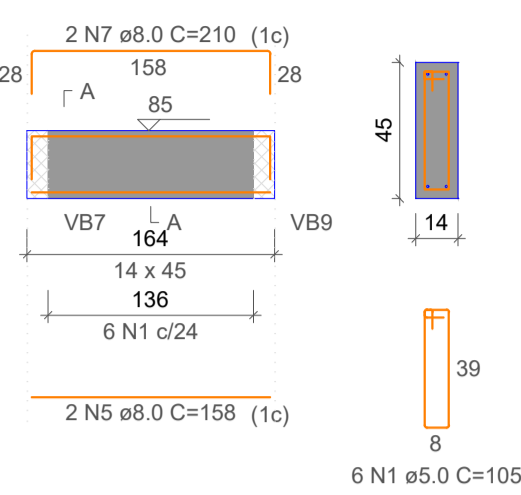

VB4
ESC 1:50

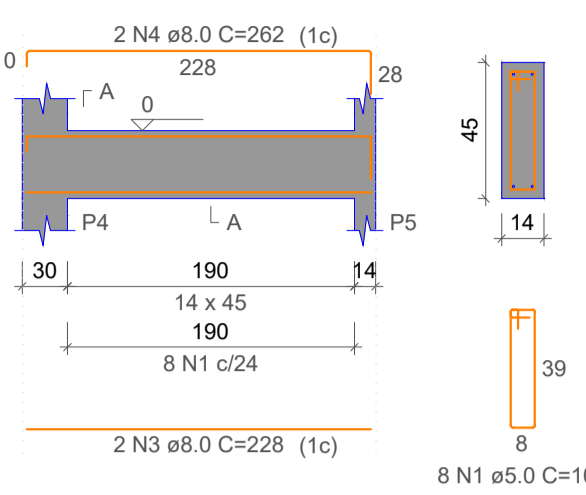

VB5
ESC 1:50

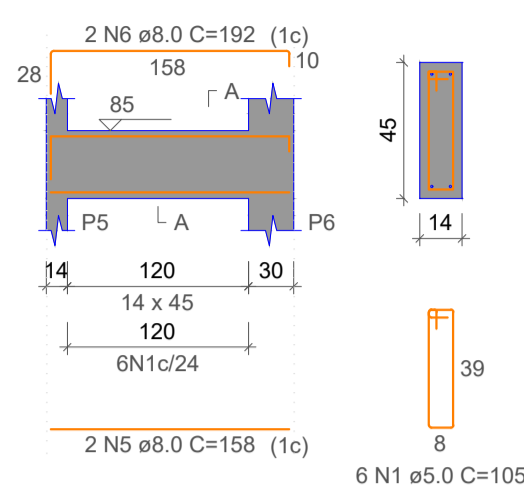

VB6
ESC 1:50

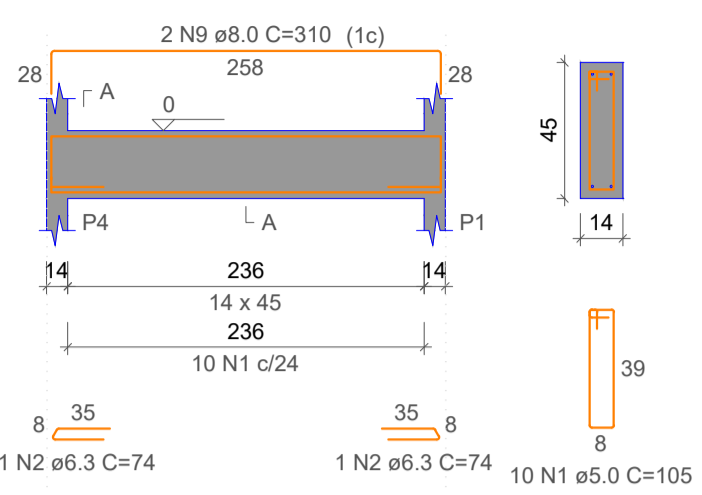

VB7
ESC 1:50

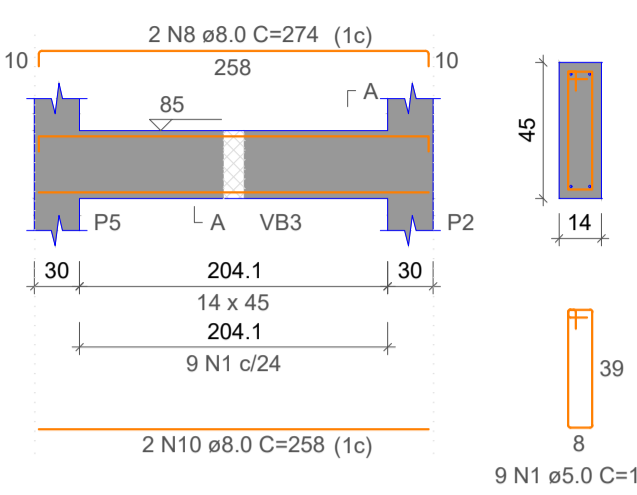

VB8
ESC 1:50

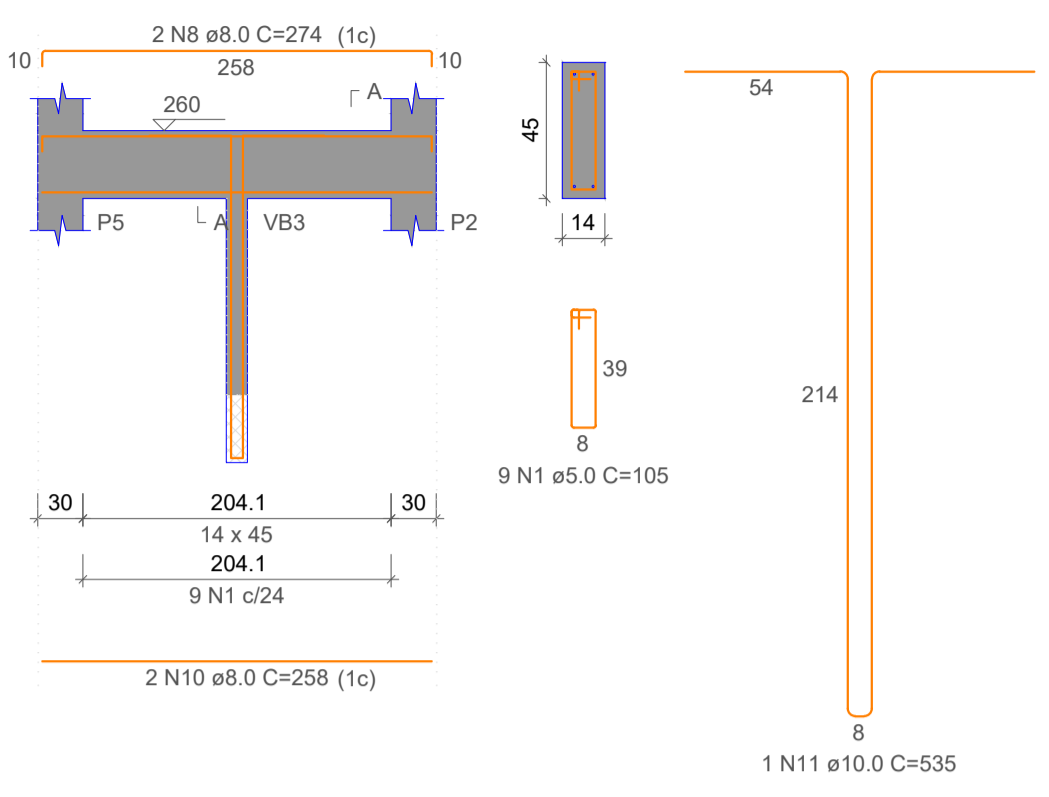

VB9
ESC 1:50

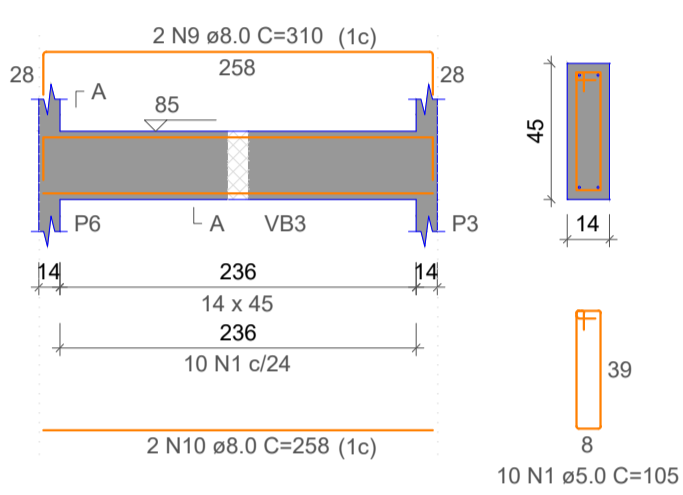

RELAÇÃO DO AÇO

AÇO	N	DIAM (mm)	QUANT	C.UNIT (cm)	C.TOTAL (cm)
CA60	1	5.0	72	105	7560
CA50	2	6.3	2	74	148
	3	8.0	4	228	912
	4	8.0	4	262	1048
	5	8.0	6	158	948
	6	8.0	4	192	768
	7	8.0	2	210	420
	8	8.0	6	274	1644
	9	8.0	4	310	1240
	10	8.0	6	258	1548
	11	10.0	1	535	535

RESUMO DO AÇO

AÇO	DIAM (mm)	C.TOTAL (m)	PESO + 10% (kg)
CA50	6.3	1.5	0.4
	8.0	85.3	37
	10.0	5.4	3.6
	5.0	75.6	12.8
PESO TOTAL (kg)			
CA50		41	
CA60		12.8	

Volume de concreto (C-25) = 1.04 m³
Área de forma = 17.17 m²

VB3_1
ESC 1:50

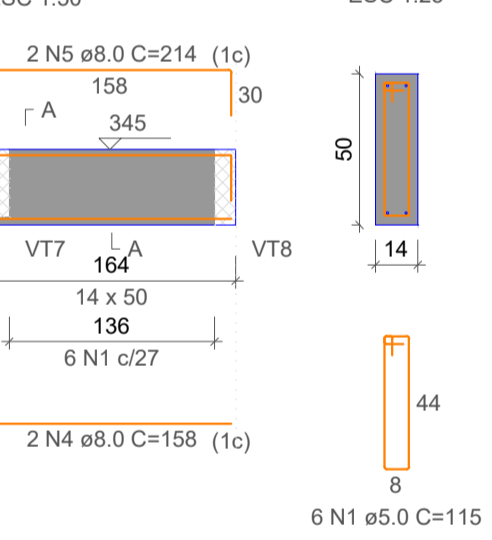

VT1
ESC 1:50

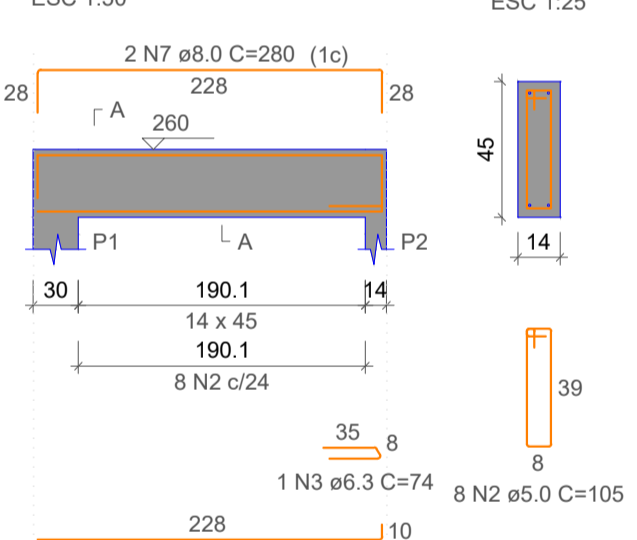

VT2
ESC 1:50

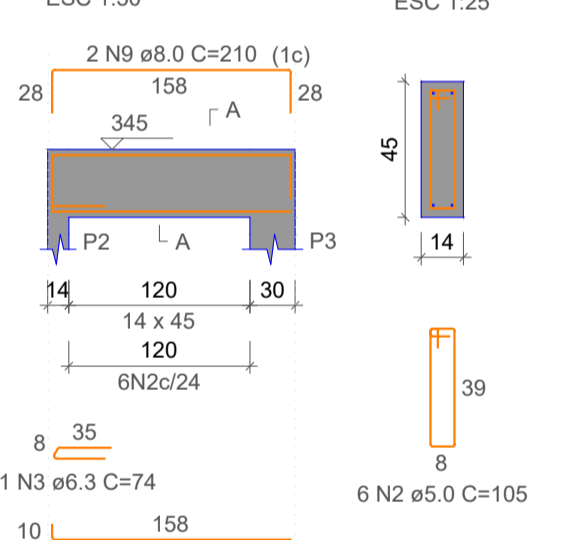

VT3
ESC 1:50

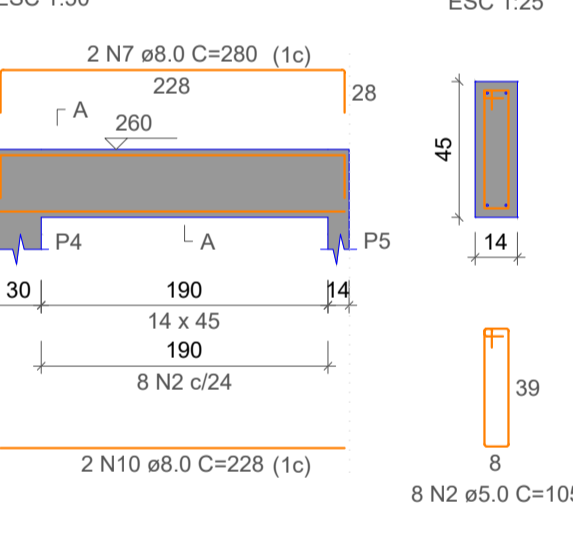

VT4
ESC 1:50

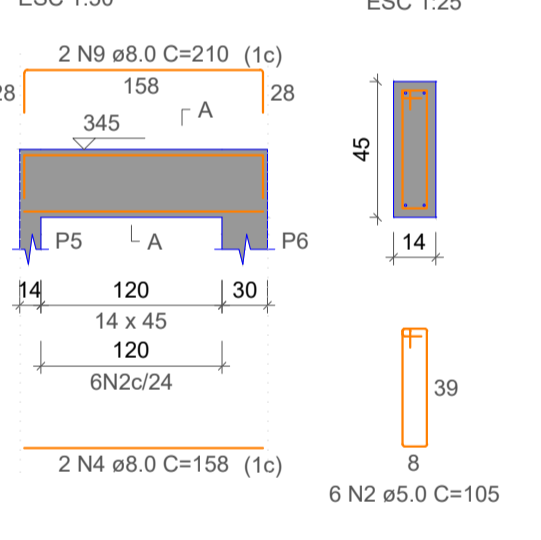

VT5
ESC 1:50

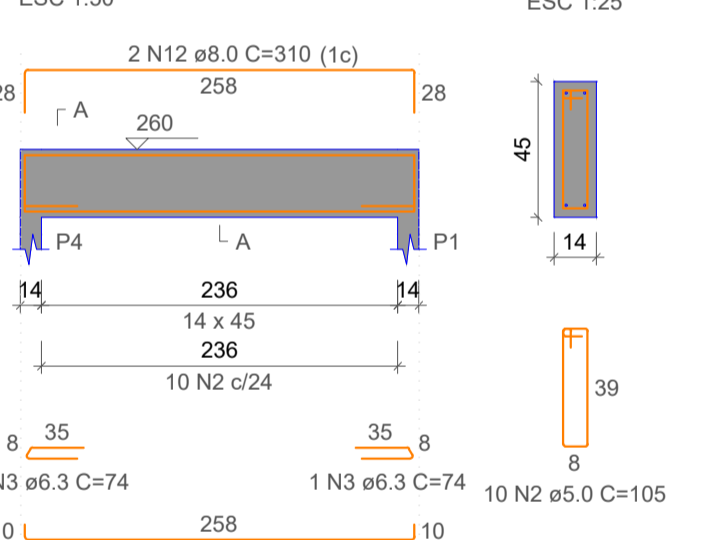

VT6
ESC 1:50

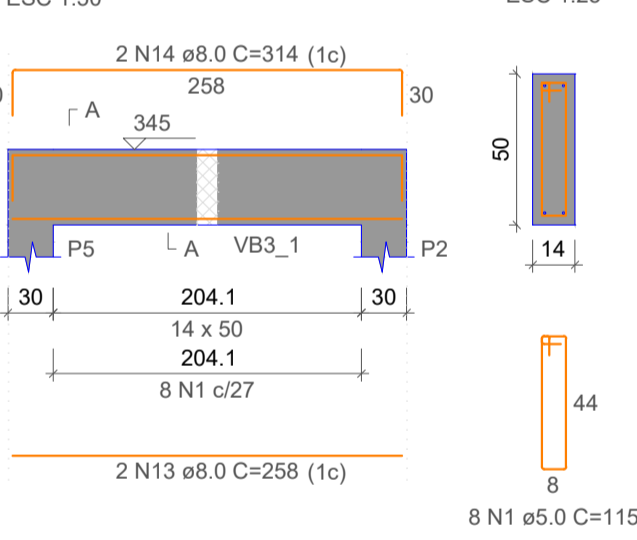

RELAÇÃO DO AÇO

AÇO	N	DIAM (mm)	QUANT	C.UNIT (cm)	C.TOTAL (cm)
CA60	1	5.0	23	115	2645
CA50	2	5.0	47	105	4935
	3	6.3	4	74	296
	4	8.0	4	158	632
	5	8.0	2	214	428
	6	8.0	2	236	472
	7	8.0	4	280	1120
	8	8.0	2	165	332
	9	8.0	4	210	840
	10	8.0	2	228	456
	11	8.0	2	274	548
	12	8.0	4	310	1240
	13	8.0	6	258	1548
	14	8.0	4	314	1256
	15	10.0	1	195	195

RESUMO DO AÇO

AÇO	DIAM (mm)	C.TOTAL (m)	PESO + 10% (kg)
CA50	6.3	3	0.8
	8.0	88.7	38.5
	10.0	2	1.3
	5.0	75.8	12.9
PESO TOTAL (kg)			
CA50		40.6	
CA60		12.9	

Volume de concreto (C-25) = 1.08 m³
Área de forma = 17.22 m²

VT7
ESC 1:50

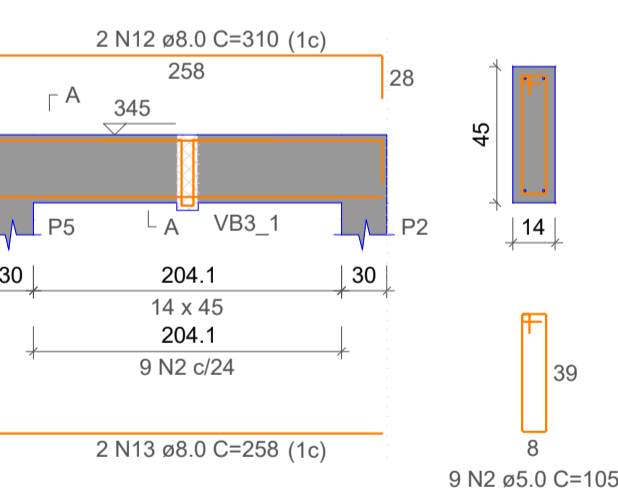

SUSPENSÃO VB3_1
ESC 1:25

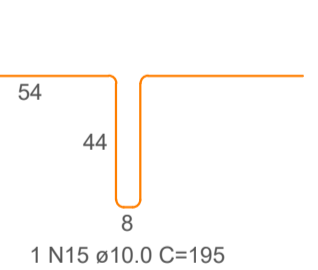

VT8
ESC 1:50

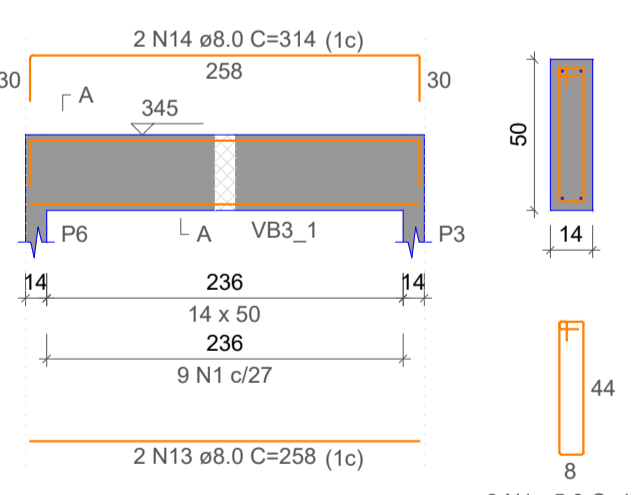

PREFEITURA DE FEIRA DE SANTANA
Secretaria de Planejamento
Avenida Sampaio 344 Centro
Feira de Santana - Ba - Tel. 75 3602-8352

NOME DO PROJETO: QUIOSQUE PRAÇA DA GABRIELA

REFERÊNCIA: PROJETO ESTRUTURAL VIGAS BALDRAME E VIGAS TERREO

PRANCHA Nº: EST 04/04

ENGENHEIRO: Distrito de Tiquaruçu, Feira de Santana-BA

RESPONSÁVEL TÉCNICO: Matheus Cardoso Santos Crea: 3000143939

DATA: 04/2028

ESCALA: 1/100

REVISÃO: 00

ARQUIVO