

RELAÇÃO DO AÇO

CAISO	N	DIAM (mm)	QUANT	C.UNIT (cm)	C.TOTAL (cm)
V1	1	5,0	513	37	49261
V2	2	5,0	54	145	7830
V3	3	5,0	36	77	2772
V4	4	5,0	11	137	1507
V5	5	5,0	2	557	1914
V6	6	5,0	2	470	940
V7	7	5,0	2	244	488
V8	8	5,0	2	244	488
V9	9	5,0	2	244	488
V10	10	5,0	2	244	488
V11	11	5,0	2	244	488
V12	12	5,0	2	244	488
V13	13	5,0	2	211	422
V14	14	5,0	2	167	334
V15	15	5,0	2	155	310
V16	16	5,0	2	155	310
V17	17	5,0	2	917	1634
V18	18	5,0	2	966	1932
V19	19	5,0	2	189	378
V20	20	5,0	2	407	814
V21	21	5,0	2	151	302
V22	22	5,0	2	200	400
V23	23	5,0	2	138	276
V24	24	5,0	2	150	300
V25	25	5,0	2	138	276
V26	26	5,0	2	594	3564
V27	27	5,0	2	594	3564
V28	28	5,0	2	594	3564
V29	29	5,0	2	251	502
V30	30	5,0	2	250	500
V31	31	5,0	2	313	626
V32	32	5,0	2	303	606
V33	33	5,0	2	326	652
V34	34	5,0	2	345	690
V35	35	5,0	2	381	762
V36	36	5,0	2	381	762
V37	37	5,0	2	671	1342
V38	38	5,0	2	1148	3444
V39	39	10,0	3	1053	3159
V40	40	10,0	3	250	750
V41	41	10,0	2	965	1930
V42	42	10,0	2	650	1300
V43	43	10,0	2	111	222
V44	44	10,0	2	301	602
V45	45	10,0	2	727	1454
V46	46	10,0	2	544	1088
V47	47	10,0	2	583	1166
V48	48	10,0	2	583	1166
V49	49	10,0	2	583	1166
V50	50	10,0	2	211	422
V51	51	10,0	2	313	626
V52	52	10,0	2	352	704
V53	53	10,0	2	323	646
V54	54	10,0	2	354	708
V55	55	10,0	2	772	1544
V56	56	10,0	2	612	1224

RESUMO DO AÇO

CAISO	N	DIAM (mm)	C.TOTAL (m)	PESO + 10% (kg)
CAISO	1	5,0	422,4	183,3
CAISO	2	10,0	244,1	166,6
CAISO	3	5,0	618,7	104,9

PESO TOTAL (kg): 454,8

CAISO 348,1

CAISO 104,9

Volume de concreto (C-25) = 7,69 m³

Área de forma = 115,28 m²

VIGAS DO PAVIMENTO DA CAPELA (NÍVEL 500)



ARMAÇÃO SUPERIOR DA RAMPA E PATAMAR

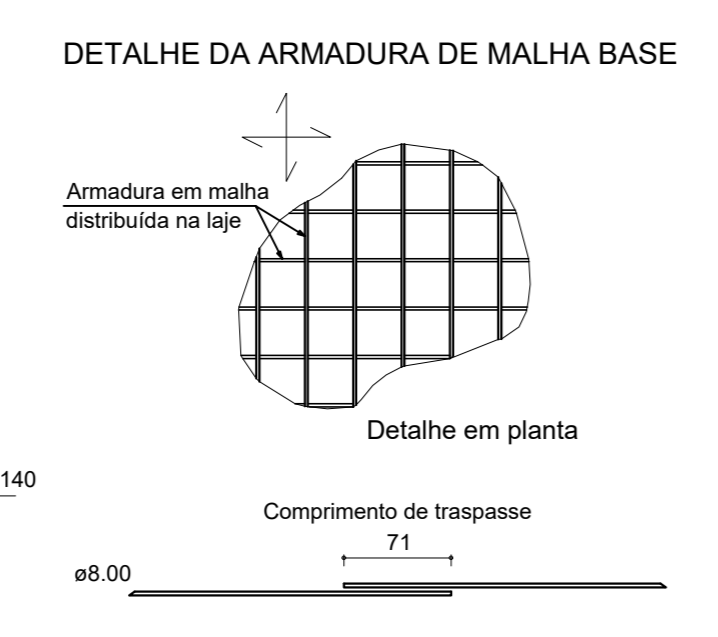

ARMAÇÃO INFERIOR DA RAMPA E PATAMAR

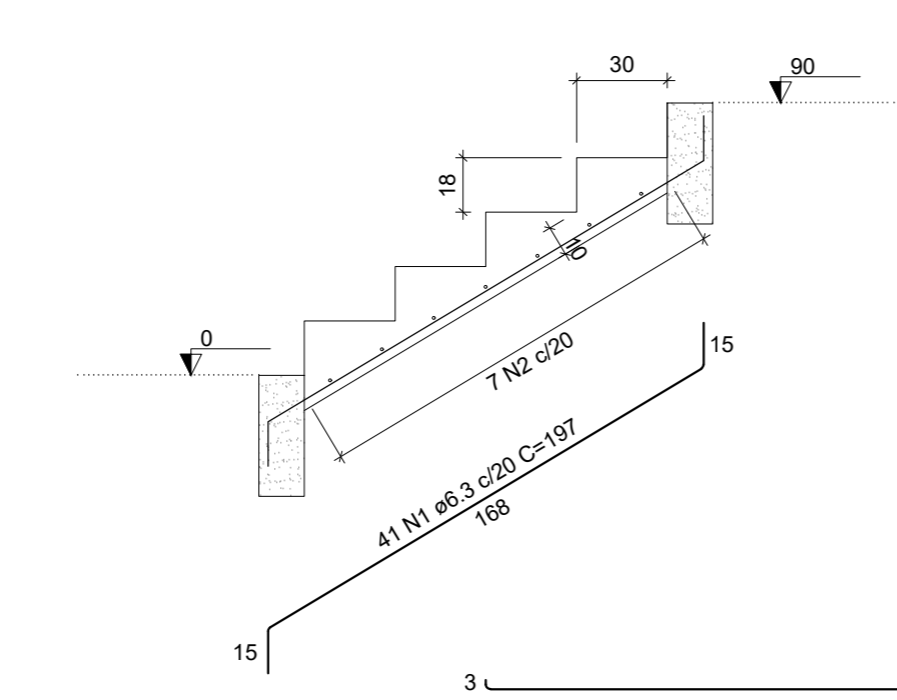
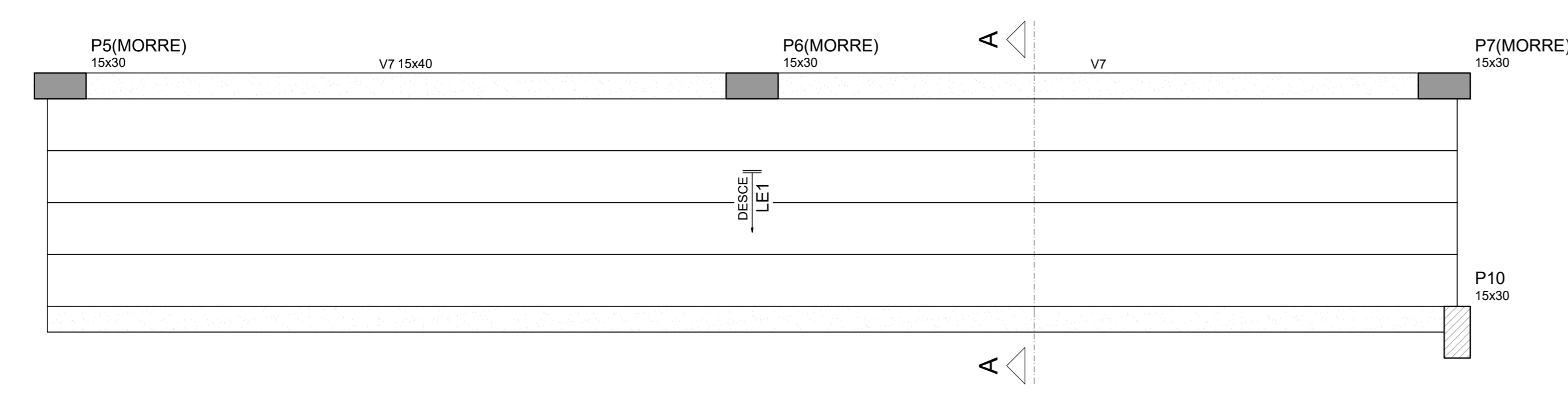

RELAÇÃO DO AÇO

CAISO	N	DIAM (mm)	QUANT	C.UNIT (cm)	C.TOTAL (cm)
CAISO	1	6,3	41	197	8077
CAISO	2	6,3	7	811	5677

RESUMO DO AÇO

CAISO	DIAM (mm)	C.TOTAL (m)	PESO + 10% (kg)
CAISO	6,3	137,5	37

Volume de concreto (C-25) = 2,17 m³

Área de forma = 19,23 m²

CORTE A-A (LE1)

MILENA GONÇALVES

PROJETO ESTRUTURAL

DESCRIÇÃO DO PROJETO: PROJETO ESTRUTURAL PRAÇA DA SAUDADE - CAPELA

CONTEÚDO: FUNDAÇÃO, RAMPA E ESCADA DO NÍVEL DA CAPELA (+500CM)

PROPRIETÁRIO: PREFEITURA MUNICIPAL DE TURMALINA - CNPJ: 25.324.187/0001-00

RESPONSÁVEL TÉCNICO: MILENA GONÇALVES DE SOUZA - DREA/ENG: 345328/D

ENDEREÇO DA OBRA: PRAÇA DA SAUDADE, CEP: 39660-000, TURMALINA/MG

DATA: OUTUBRO/2025

FRANCHA: 8/10

CONTATO ENG: 38 9 9151-3570

ENDEREÇO ENG: AV. LAURO MACHADO, CENTRO, 42, SL. 01

FOLHA: AO