

B21

2xC30

PLANTA

Escala - - - - - 1:50

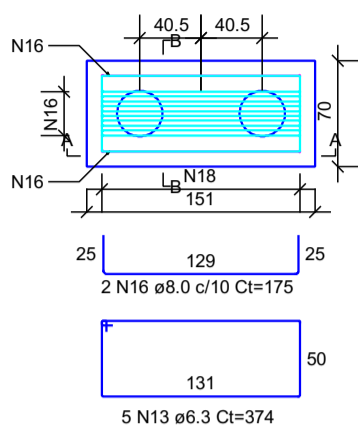

CORTE A-A

Escala - - - - - 1:50

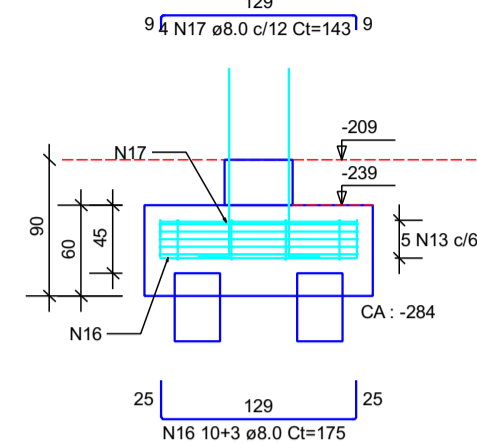

CORTE B-B

Escala - - - - - 1:50

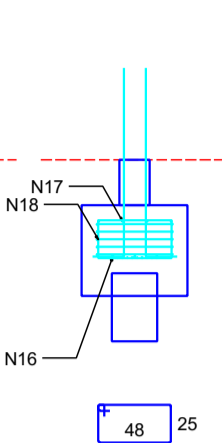

P21

SUBSOLO - L1

SEÇÃO

Escala - - - - - 1:30

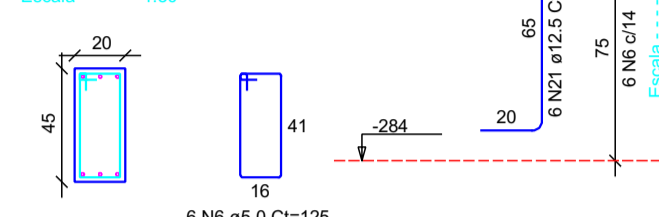

B33

2xC30

PLANTA

Escala - - - - - 1:50

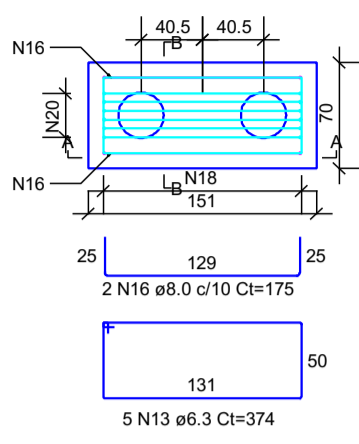

CORTE A-A

Escala - - - - - 1:50

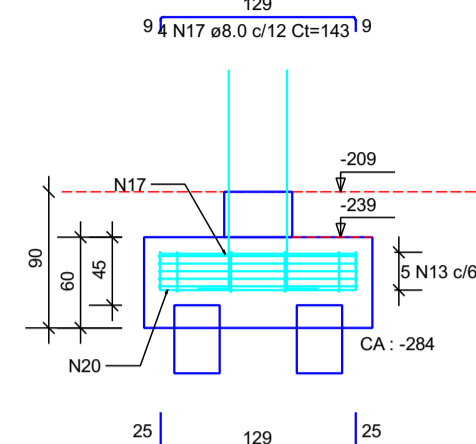

CORTE B-B

Escala - - - - - 1:50

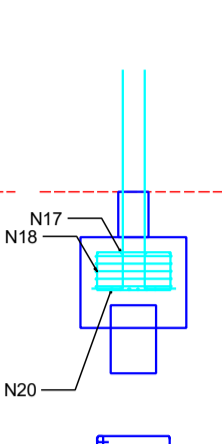

P33

SUBSOLO - L1

SEÇÃO

Escala - - - - - 1:30

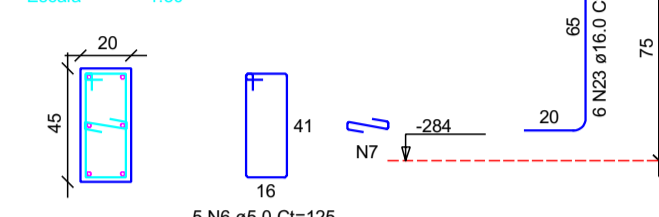

B4-5

2xC30

PLANTA

Escala - - - - - 1:50

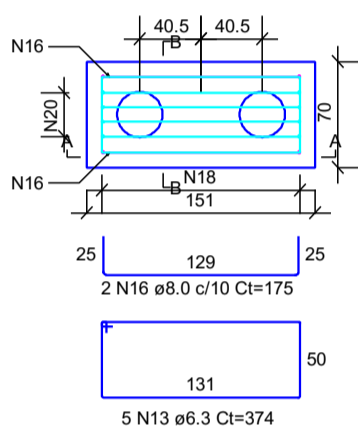

CORTE A-A

Escala - - - - - 1:50

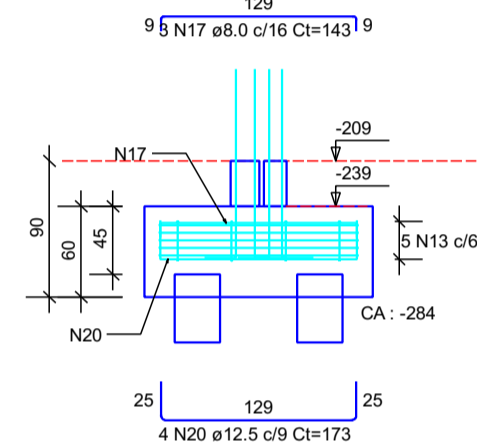

CORTE B-B

Escala - - - - - 1:50

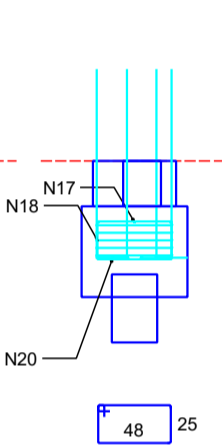

P4

SUBSOLO - L1

SEÇÃO

Escala - - - - - 1:30

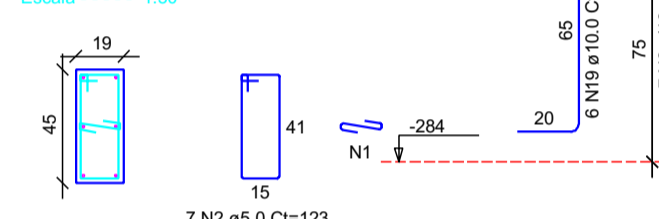

P5

SUBSOLO - L1

SEÇÃO

Escala - - - - - 1:30

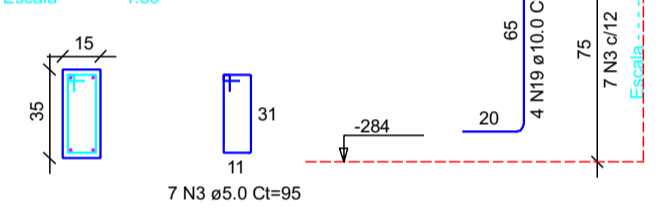

B35

2xC30

PLANTA

Escala - - - - - 1:50

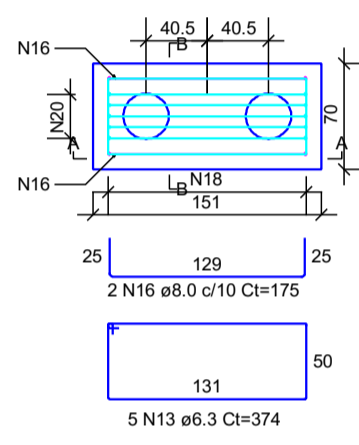

CORTE A-A

Escala - - - - - 1:50

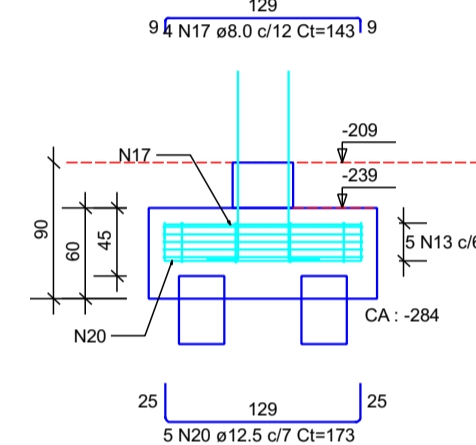

CORTE B-B

Escala - - - - - 1:50

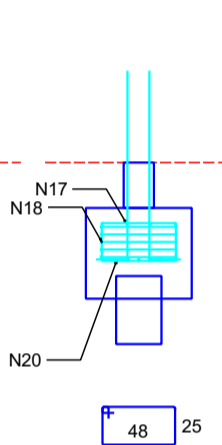

P35

SUBSOLO - L1

SEÇÃO

Escala - - - - - 1:30

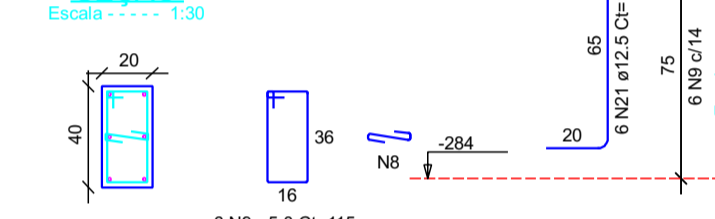

RELAÇÃO DO AÇO

AÇO	N	DIAM (mm)	QUANT	C.UNIT (cm)	C.TOTAL (cm)
CA60	1	5.0	14	30	420
	2	5.0	7	123	861
	3	5.0	27	95	2565
	4	5.0	6	30	180
	5	5.0	12	103	1236
	6	5.0	11	125	1375
	7	5.0	5	31	155
	8	5.0	6	31	186
	9	5.0	6	115	690
	10	5.0	7	113	791
	11	5.0	6	26	156
	12	5.0	6	115	690
	13	6.3	35	374	13090
	14	6.3	5	212	1060
	15	6.3	2	208	416
	16	8.0	27	175	4725
	17	8.0	27	143	3861
	18	8.0	28	158	4424
	19	10.0	24	143	3432
	20	12.5	28	173	4844
	21	12.5	26	142	3692
	22	12.5	6	147	882
	23	16.0	6	161	966

RESUMO DO AÇO

AÇO	DIAM (mm)	C.TOTAL (m)	PESO + 10% (kg)
CA50	6.3	145.7	39.2
	8.0	130.1	56.5
	10.0	34.3	23.3
	12.5	94.2	99.8
	16.0	9.7	16.8
CA60	5.0	93	15.8
PESO TOTAL (kg)			
CA50		235.5	
CA60		15.8	

Volume de concreto (C-30) = 4.85 m³
Área de forma = 24.47 m²

B18-19

2xC30

PLANTA

Escala - - - - - 1:50

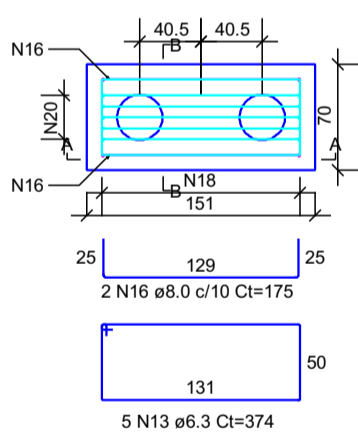

CORTE A-A

Escala - - - - - 1:50

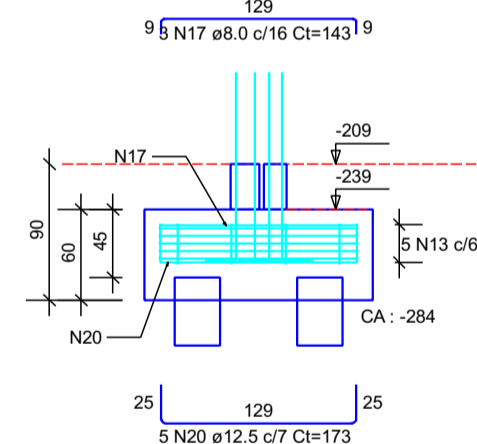

CORTE B-B

Escala - - - - - 1:50

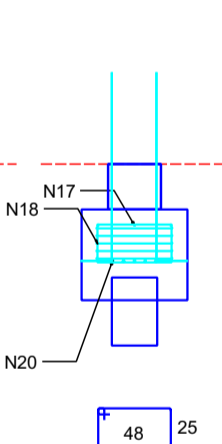

P18

SUBSOLO - L1

SEÇÃO

Escala - - - - - 1:30

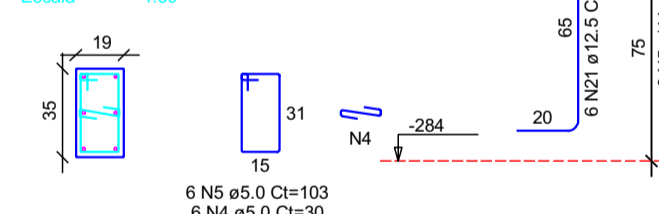

P19

SUBSOLO - L1

SEÇÃO

Escala - - - - - 1:30

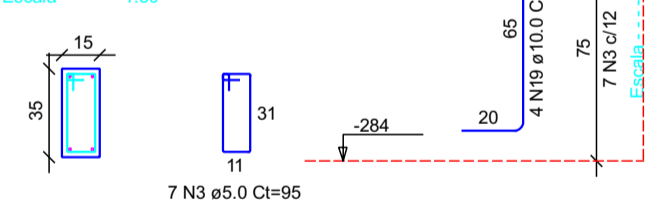

B27-28

2xC30

PLANTA

Escala - - - - - 1:50

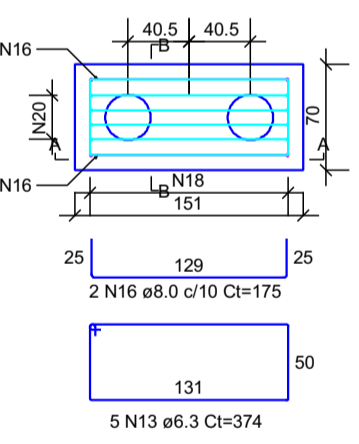

CORTE A-A

Escala - - - - - 1:50

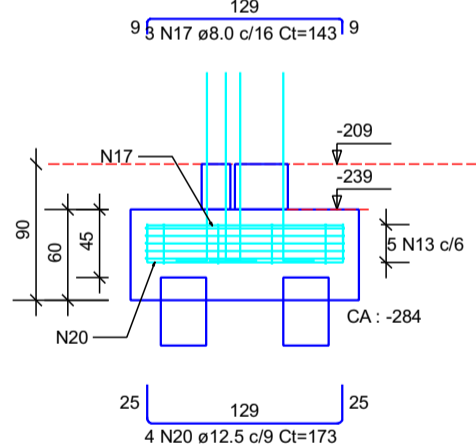

CORTE B-B

Escala - - - - - 1:50

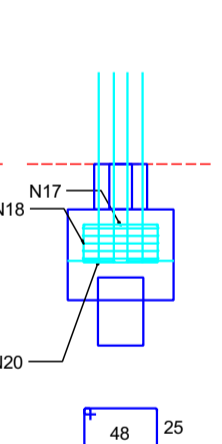

P27

SUBSOLO - L1

SEÇÃO

Escala - - - - - 1:30

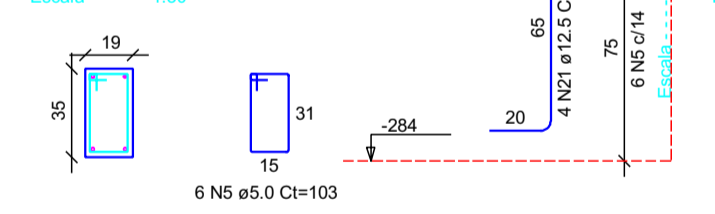

P28

SUBSOLO - L1

SEÇÃO

Escala - - - - - 1:30

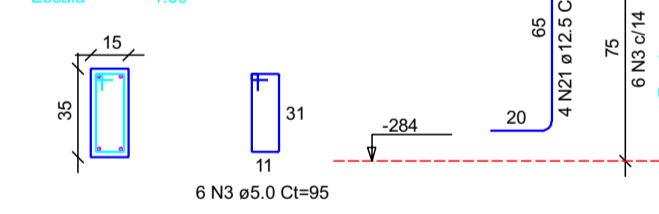

B40-41

2xC30

PLANTA

Escala - - - - - 1:50

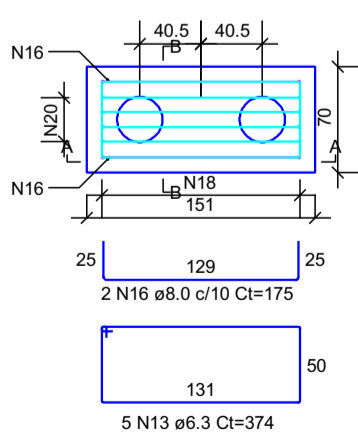

CORTE A-A

Escala - - - - - 1:50

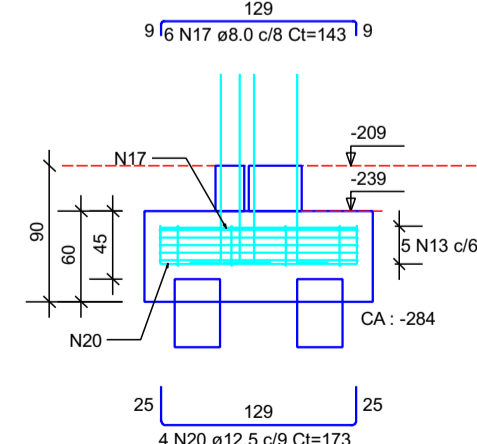

CORTE B-B

Escala - - - - - 1:50

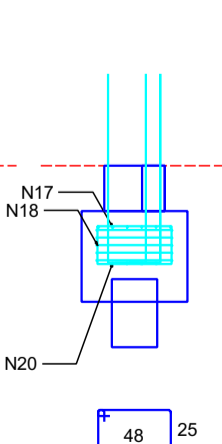

P40

SUBSOLO - L1

SEÇÃO

Escala - - - - - 1:30

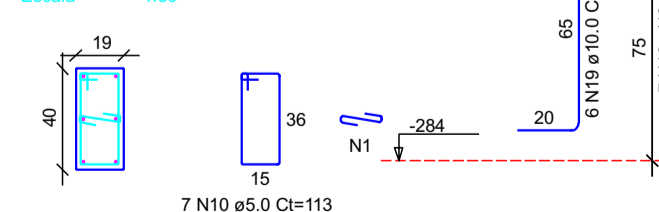

P41

SUBSOLO - L1

SEÇÃO

Escala - - - - - 1:30

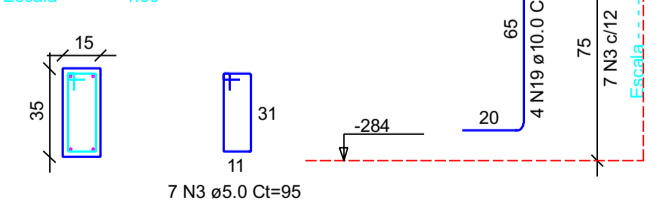

B50

1xC30

PLANTA

Escala - - - - - 1:50

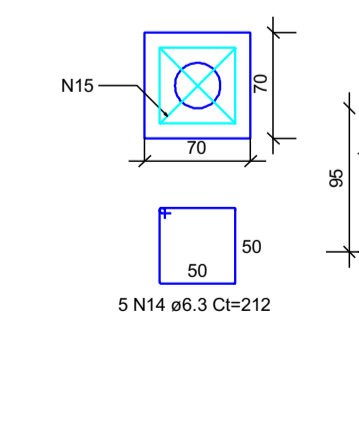

CORTE

Escala - - - - - 1:50

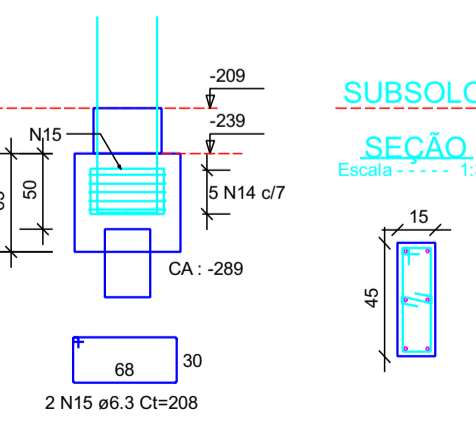

P50

SUBSOLO - L1

SEÇÃO

Escala - - - - - 1:30

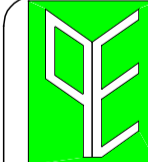
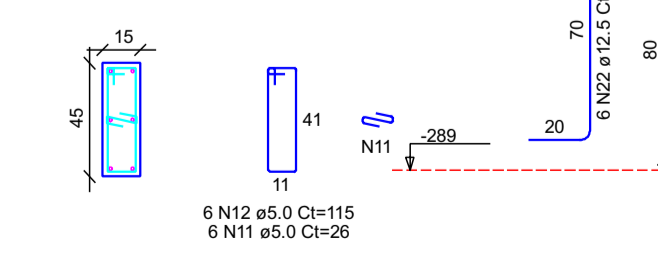

José Roberto Troca
Pouso Alegre - Fone: (35) 99966-3333
jtroca@yahoo.com.br

PROJETO ESTRUTURAL

OBRA: Comercial - Saúde
ENDEREÇO: R. Pedro Ribeiro Arantes - Quadra C - Lot. Vale dos Pinheiros - São Lourenço - MG

RESPONSÁVEL TÉCNICO: JOSÉ ROBERTO TROCA - ENG° CIVIL CREA: 2330/D

FRANCHA: DETALHES E ARMAÇÕES BLOCOS SUBSOLO

PAVIMENTO: SUBSOLO

PROPRIETÁRIO: CONSÓRCIO INT S. CIS - CIRCUITOS ÁGUAS
CNPJ: 71.203.715/0001-90

REVISÃO: **02/24**
ÁREA: 1.448,30 M² DATA: Jun/2025