

1 CALÇADA
1:75

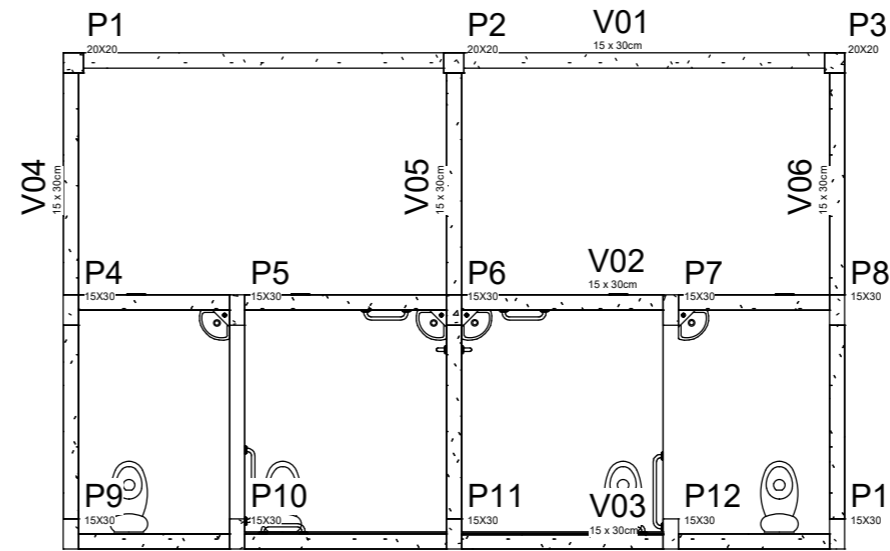

2 PÁV. SUPERIOR
1:75

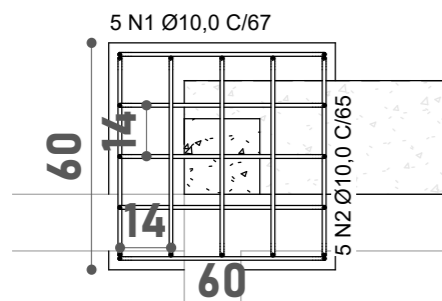

4 Sapata S1-S13
1:20

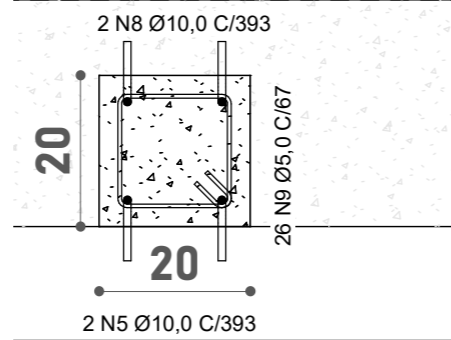

5 PILAR P1-P3
1:10

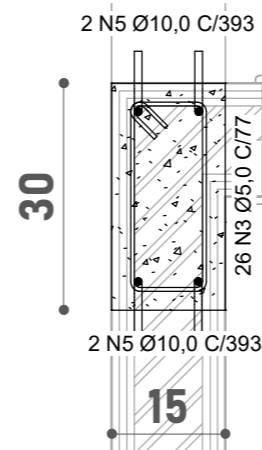

6 PILAR P4-P13
1:10

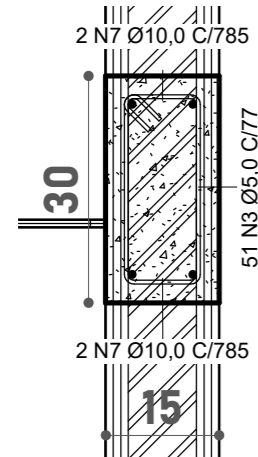

7 VIGAS V01-V06
1:10

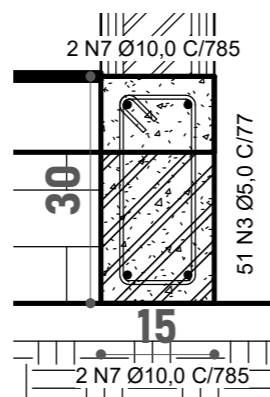

8 VIGAS VB01-V05
1:10

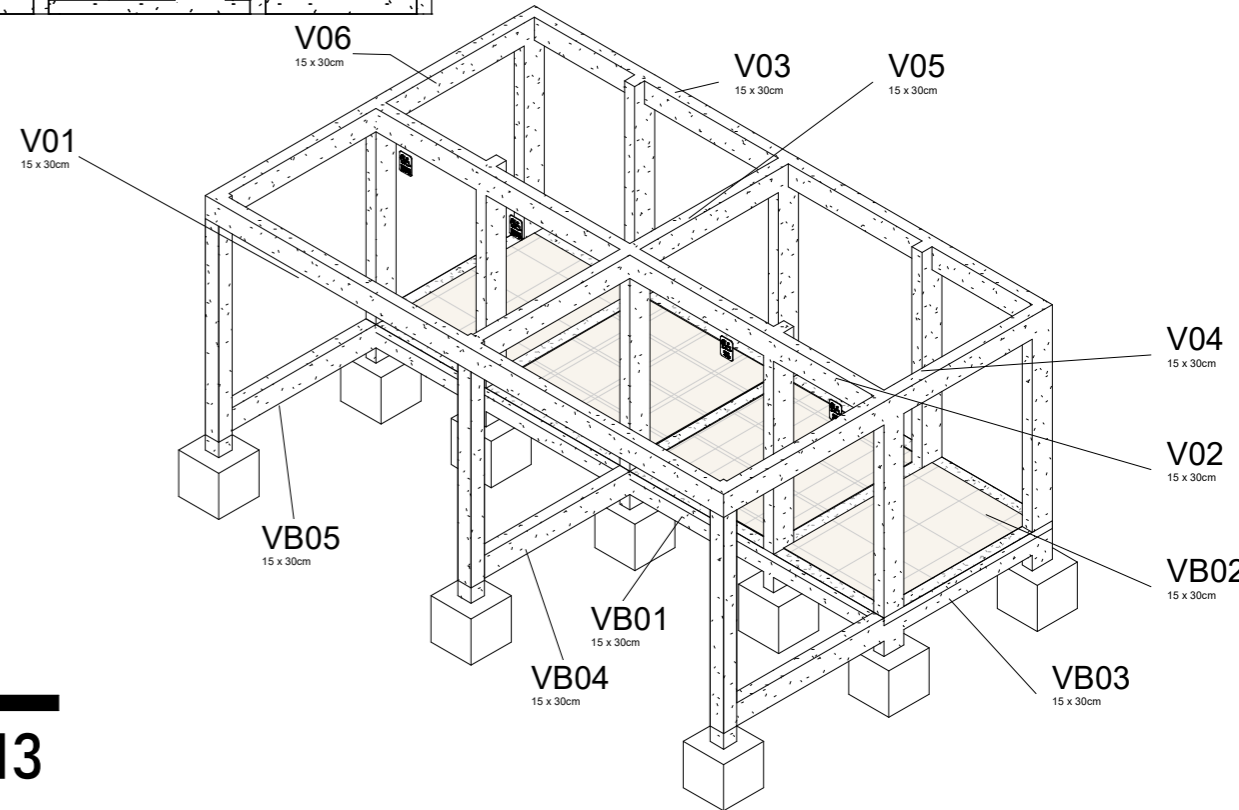

Revisão:

PREFEITURA MUNICIPAL DE QUARAÍ

Obra/ Serviço: Construção Quadra e Banheiro Zona Norte

Local: Praça Zona Norte

Prancha: Estrutural Banheiro

Área: 45,65m² Escala: Como indicado Data: 15/01/2026 Folha: 06



Jeferson da Silva Pires
Prefeito Municipal

Ricardo Lopes de Assis
Engenheiro Civil